

INTERIOR DESIGN

Stefano Ricci

“While maintaining
indisputable elegance,
my collections
have always been
a concrete testimonial
of how design can
become a lifestyle.”

Stefano Ricci, company Founder and Designer

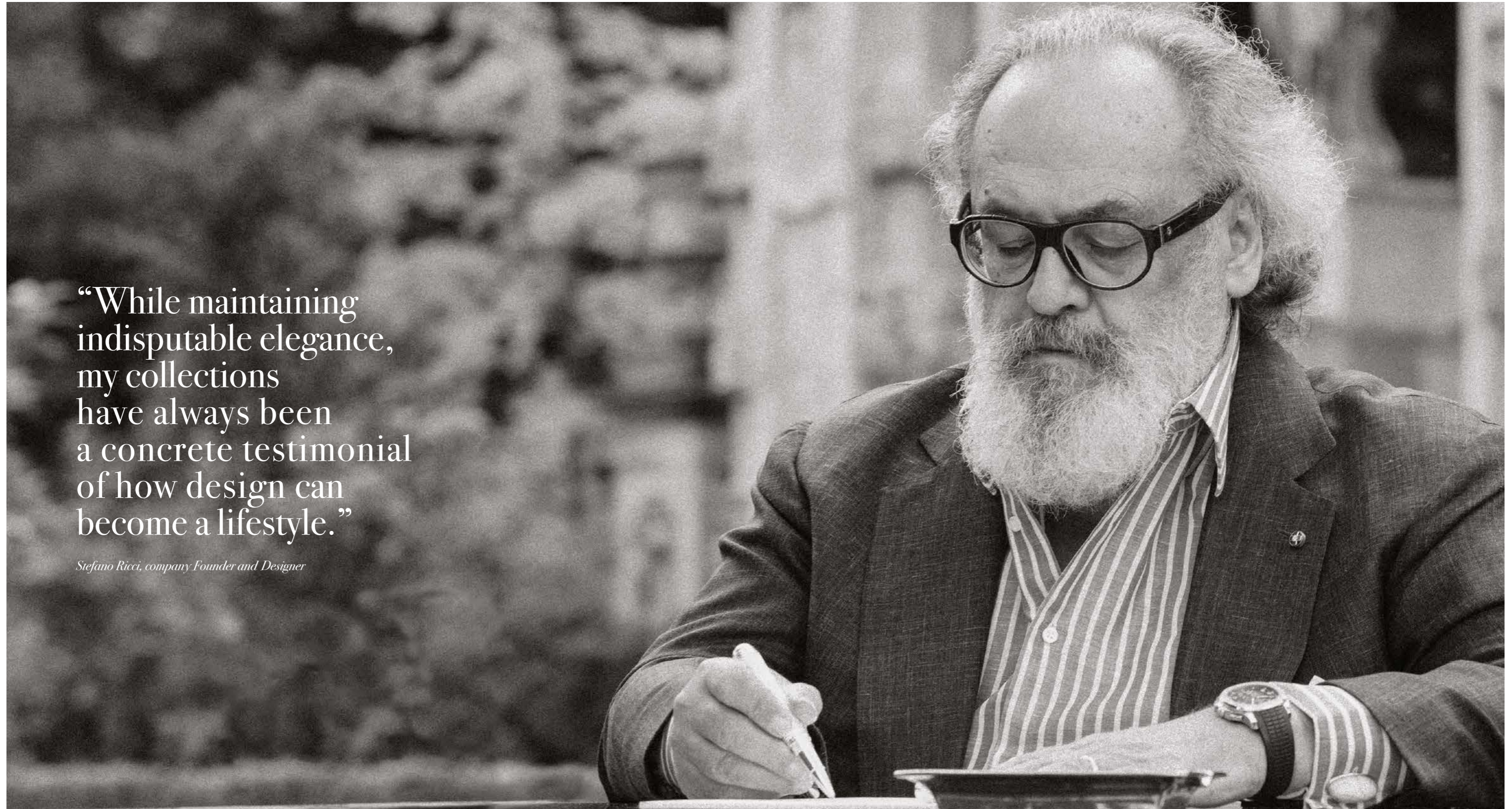



STEFANO RICCI
HOME

INTERIOR DESIGN

4

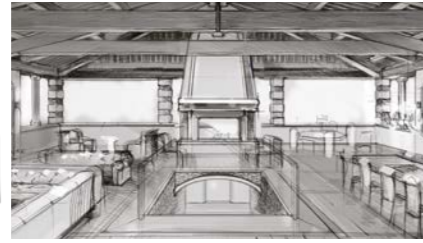

**THE WORLD OF
STEFANO RICCI**

8



**FROM THE IDEA
TO THE TAILORED CONCEPT**

16



PRESIDENTIAL OFFICES

- 24 Classic Design Concept
Briar-root Wood line
Tuscan Full-travertine line
- 26 *Signoria line*
- 28 Contemporary Design Concept
Black Briar-root Wood line
Pietra Serena line

32



**PRIVATE RESIDENCES
& ESTATES**

- 34 Living & Dining Room Proposals
- 42 *Belvedere line*
- 46 *Chiselled Lighting line*
- 48 *Pure Crystal line*
- 58 *Loggia line*
- 60 *Finished Stone line*
- 74 Bedroom & Bathroom proposals

82



HOTEL SUITES & LOUNGES

- 84 Stefano Ricci Presidential Suite
at Grand Hotel Principe di Piemonte - Viareggio
- 90 Stefano Ricci La Rocca - Castelfalfi
- 98 Stefano Ricci Shanghai Mansion
- 102 Casa Stefano Ricci Singapore
- 110 Casa Stefano Ricci Beijing
- 118 Sindalah Yacht Club designed by Stefano Ricci
- 124 *Signoria line*
- 128 *Fortezza line*
- 136 Hall & Suite Proposals
- 144 Corridor & Cellar Proposals
- 154 Indoor/Outdoor Proposals

THE WORLD OF STEFANO RICCI

by Ettore Mocchetti

Architect, former Editor-in-Chief of AD Italia (1981-2015 and 2016-2020)

Stefano Ricci is a master of Design who, far from industrial canons, expresses a luxury lifestyle created to meet the needs of a wealthy and cultured clientele.

In other words, he does not create luxury for its own sake but for the excellence that is reserved for lovers of beauty.

Observing his creations, not only the individual elements but also the opulence of his boutiques, you can breathe in the aura of Florentine magnificence. This effect stems from the combination of travertine marble with brown Californian briar-root wood and the more contemporary interpretation of *pietra serena* stone with black Californian briar-root wood.

All works have the same meticulous attention to detail that we are used to recognising in a connoisseur's wardrobe, not full of fashion but quality, combined with a well-defined style. His is a coherent, pertinent aesthetic alignment. Products are not intended for mass production.

I would rather say that the distinguishing element is characterised by the artisanal value, one that is the legitimate heir of the rich tradition of knowledge deriving from workshops. Think of Benvenuto Cellini's salt cellar and compare it to an element of SR HOME. You will rediscover

the taste of true luxury, which means something well-crafted, to perfection, without thinking about the final cost. Because the product is destined for the elite. Just as the Renaissance artefacts were made to satisfy the wishes of the Medici.

There is a lot of Florence in Stefano Ricci. The Italian spirit of style exists in his creations and high quality designs. There are few pieces made exclusively to reflect the spirit of a cosmopolitan clientele who loves to surround themselves with beauty. I understood this by entering that marvel that is *Poggio ai Segugi*. When I was invited to the Ricci family estate, made by a designer who is the envy of the world, I imagined it would be a sort of isolated retreat. I was wrong, and now know that *Poggio* is the highest testimony of an ancient rite, such as the art of hospitality and good taste.

Therefore, it is no coincidence that Stefano Ricci was officially founded at the height of the 1970s when the Made in Italy concept, now appreciated worldwide, was first introduced. It is no coincidence that today his brand's production is one of the rare examples of authentic Italian craftsmanship, made in the country considered to be the cultural heritage of the world.





DESIGNER STEFANO RICCI

When Stefano Ricci launched his first collection, he earned an international reputation as a leader in men's fashion and entrepreneurship. The designer has always drawn much of his inspiration from his Florentine heritage. His work is an expression of beauty, authenticity, tradition, and elegance. This meets his fascination with nature, further exalted by his many travels to Africa: the colours and poetry of silence are balanced by the exhilaration of being in the wild. It is a world of research, where the intelligence of the hand is an expression of the passion of the heart.

Today, he continues to conquer new areas of production and design. To achieve a calibre as high as that of the coveted and iconic STEFANO RICCI tie, which made his fame, each new venture has applied the same successful rules: perfect manufacturing, top-quality materials and exclusive designs. These standards have now become the basis for the overarching themes found in SR HOME interiors; every detail, no matter how small, is considered with great care.



FROM THE IDEA TO THE TAILORED CONCEPT

Wherever the project may be, Stefano Ricci will personally send his selected team of architects who specialise in offering tailored proposals and the exclusive service that defines the SR World. Recognised for the high level of personalisation that is the cornerstone of the Maison's menswear offerings, STEFANO RICCI now proposes bespoke turnkey services from the architectural concept to its luxury lifestyle collections.

Every piece from SR HOME is envisioned with a passion for creating unique proposals fit for a discerning clientele. To ensure products of absolute excellence, the materials used have been specially selected with the utmost attention to quality, colour, shape and form. To provide this flawless detailing, all furnishings are produced exclusively in Tuscany, whilst Florentine artisans travel on-site to ensure all materials are perfectly fitted to each residence.

-
- **STEP 1** Location and Space Evaluation
 - **STEP 2** On-site Technical Survey and Project Guidelines
 - **STEP 3** Architectural Concept Design and Interior Fit-Out
 - **STEP 4** Contractors Coordination, Work Management and Supervision
 - **STEP 5** Final Inspection and Delivery
-



STEFANO RICCI LIFESTYLE

Amaze, Surprise and Conquer. In the game of style, the Florentine designer looks at the desires of his clients with clever understanding. Loyal to his creativity, he aims to remain one step ahead of the needs of his cultured and cosmopolitan clientele, producing garments, accessories and intriguing lifestyle items.

The STEFANO RICCI luxury lifestyle is more than refined, authentic and rare; it is, above all, a sense of style imbued with timeless elegance. Clients are connoisseurs who search for a taste of sophistication and subtlety, driven to acquire items of great quality.

The lifestyle offering expands beyond garments for the SR man and juniors, designed to accompany the wearer throughout the occasions of each day.

Accessories, ranging from handcrafted leather goods and beautifully functional cigar lighters and cutters to items for fine dining and home decoration, all represent reinterpretations of tradition with new research and experimentation. Together with the meticulously constructed jewellery items such as precious buckles and cufflinks, these lifestyle items represent the Florentine brand's DNA.



100% MADE IN ITALY

The philosophy guiding Stefano Ricci in pursuing his vision has always been a firm belief that “Made in Italy” must remain synonymous with master craftsmanship and a unique style. Thus, from the beginning, the company's efforts have been focused on achieving the highest quality at each stage of production, from the careful selection of raw materials to the sophisticated manufacturing involved in creating each design. For Stefano Ricci, the use of exclusive materials is much more than just an aesthetic: it is a fully fledged style amplifier that allows the innovative, experimental, and refined vein of the Florentine Maison to shine through.

The unmistakable design found in SR HOME interiors is made possible by the company's inherent use of certain luxury materials: Californian briar-root wood, Tuscan travertine marble, Pietra serena sandstone, exclusive leathers and precious fabrics from the historic silk mill, Antico Setificio Fiorentino (ASF). The ASF has produced exquisite fabrics on handlooms and semi-mechanical looms since 1786. These textiles are emblematic of the group's philosophy: 100% Made in Italy, or better yet, Made in Florence.



PRESIDENTIAL OFFICES

The STEFANO RICCI Interior Design services enter the business world, offering tailored, luxurious presidential offices for entrepreneurs, heads of state and businessmen worldwide. The proposals are shaped by the unique needs of an elite cosmopolitan clientele who seek to embody a gentleman's style in the pursuit of their enterprises. Bespoke interior proposals boast iconic SR elements that reflect an energetic, robust character, with bold accents.

Featuring precious materials directly imported from Italy, STEFANO RICCI's company heritage inspires the presidential offices. These spaces may be envisioned with classic design concepts, from the *Briar-root Wood* line, the *Finished Stone* line and the *Tuscan Full-travertine* line. Contemporary design concepts are available as well, with a range including the *Black Briar-root Wood* line, the *Pietra Serena* line and the *Chiselled Lighting* line.



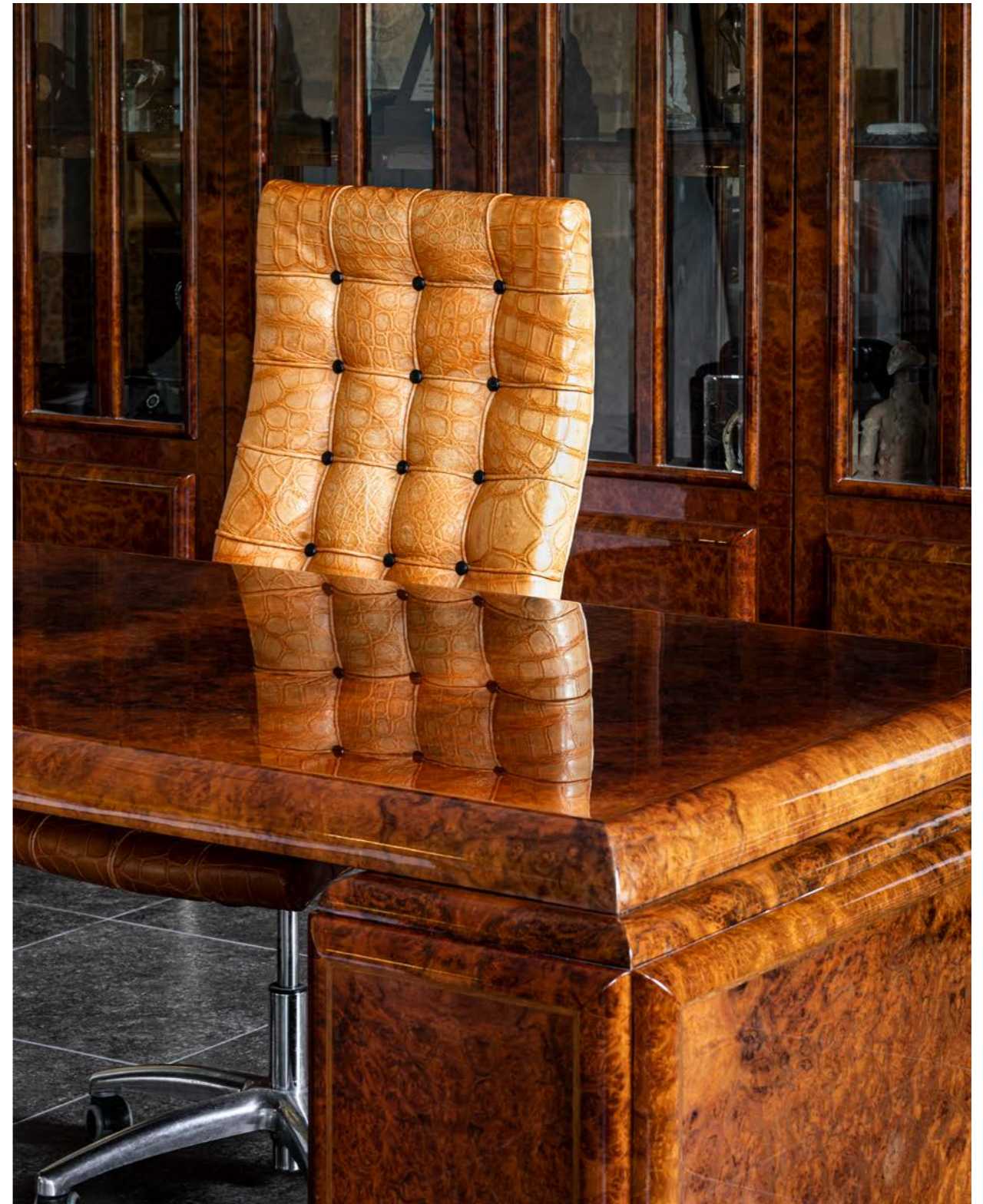





CLASSIC DESIGN CONCEPT

The *Briar-root Wood* line: Californian Briar-root wood is one of the most distinguishing features of SR HOME interiors. Its characteristically rich colour tone, complemented by the organic patterns found naturally within the wood, brings the material a natural aesthetic prominence.

This particular root originates from the Californian Walnut, which is delivered directly to the SR company headquarters in 2mm sheets to be personally selected by Stefano Ricci for each project. Choosing the best sheets means finding the most homogeneous patterns with minimal knots or imperfections. This material is perfectly integrated for a total SR classic design concept, from hand-polished executive desks and octagonal conference tables to the structure of office chairs.

The *Finished Stone* and *Tuscan Travertine* lines: Enduring stone, elegantly worked and precisely handled, is utilised within the SR classic design concept. Often used in unique claddings, the noble travertine marble originates in Rapolano Terme, Tuscany; it is cut and finished by artisans who enhance the stone's natural grace.

Within the classic design concept, a wide range of elegant and exotic leathers is offered to discerning clientele; furnishings are elevated with colourful leathers, whether on executive office chairs or office doors.



SIGNORIA EXECUTIVE CHAIR

Part of a versatile home design concept blending classic and contemporary aesthetics, the *Signoria* Line was the company's first venture into luxury furnishings. The shapes inherent in the items clearly reference the SR octagon motif, a symbol of the Maison that reflects the aesthetic balance and power of the form. The name *Signoria* is a homage to the significant influence of Florence's Renaissance government and rich traditions of artistic patronage. The proportions of the executive chair are visually impactful and lend an elegant formal presence to an SR-designed office. The chair has a hand-padded, contoured shape with a frame finished in Californian briar-root wood, a swivel and a height-adjustable base. From soft calfskin to exotic crocodile, the leather coverings available for this chair are selected from the finest and most suitable hides.



BRIAR-ROOT WOOD CONFERENCE TABLE AND CONFERENCE CHAIRS

The multi-faceted *Briar-root wood* conference table is elegantly crafted with sculptural, strong lines and a subtle octagonal shape. The fine Californian briar-root wood veneer is applied by hand with traditional techniques, and the table is equipped with an internal wiring compartment for digital devices. The conference table may be Made-to-Measure in order to adapt to varying office spaces. It may be paired with *Briar-root wood* conference chairs, combining the exceptionally unique veneer with exclusive leather or precious silk upholstery.





CONTEMPORARY DESIGN CONCEPT

The *Black Briar-root Wood* line: Californian briar-root wood plays a part in the contemporary design concept as well. Equal to the classic brown Californian briar-root wood processing, the selected roots are carefully sliced and arranged so that, when set side-by-side, adjacent cuts create symmetric, mirrored patterns. These veneers may be enhanced by contrast-coloured intaglio in White Wenge hardwood. The final finish is glossy, intriguing and without compare.

The *Pietra Serena* and *Chiselled Lighting* lines: Stones return in the contemporary concept, with an emphasis on the pietra serena which is widely appreciated in Florence's historic squares. This material is best known for its use in Florence and Tuscany, where master craftsmen are particularly adept at placing it in both artistic and architectural settings. The dignified sandstone, which has a light blue-grey tone, has a name which literally translates into the "serene stone".

The dark shades of black Californian briar-root wood are balanced by the soft tones of pietra serena sandstone, and the two materials frequently meet to create a contemporary and refined design concept. The *Chiselled Lighting* line pushes the concept further by integrating lightweight plexiglass items and fixtures that are functional and chiselled by hand to achieve a stone-like appearance.



BLACK BRIAR-ROOT WOOD EXECUTIVE DESK

The *Black briar-root wood* executive desk is fully made to measure, accommodating a variety of office layouts and personal needs. The desk has black Californian briar-root wood veneer and is characterised by strong, geometric lines that contrast with half-convex, rounded edges. The desk may be modified to include drawers and integrated lighting or a crystal tabletop with electric side compartments.



BLACK BRIAR-ROOT WOOD EXECUTIVE COFFEE TABLE

The *Black Briar-root wood* executive coffee table is coordinated to match the style of the executive desk. It may feature an inlay in light-toned woods, such as White Wenge, for contrast with the dark shades of the Californian briar-root wood. Customisations such as made-to-measure internal compartments and hidden drawers are available.

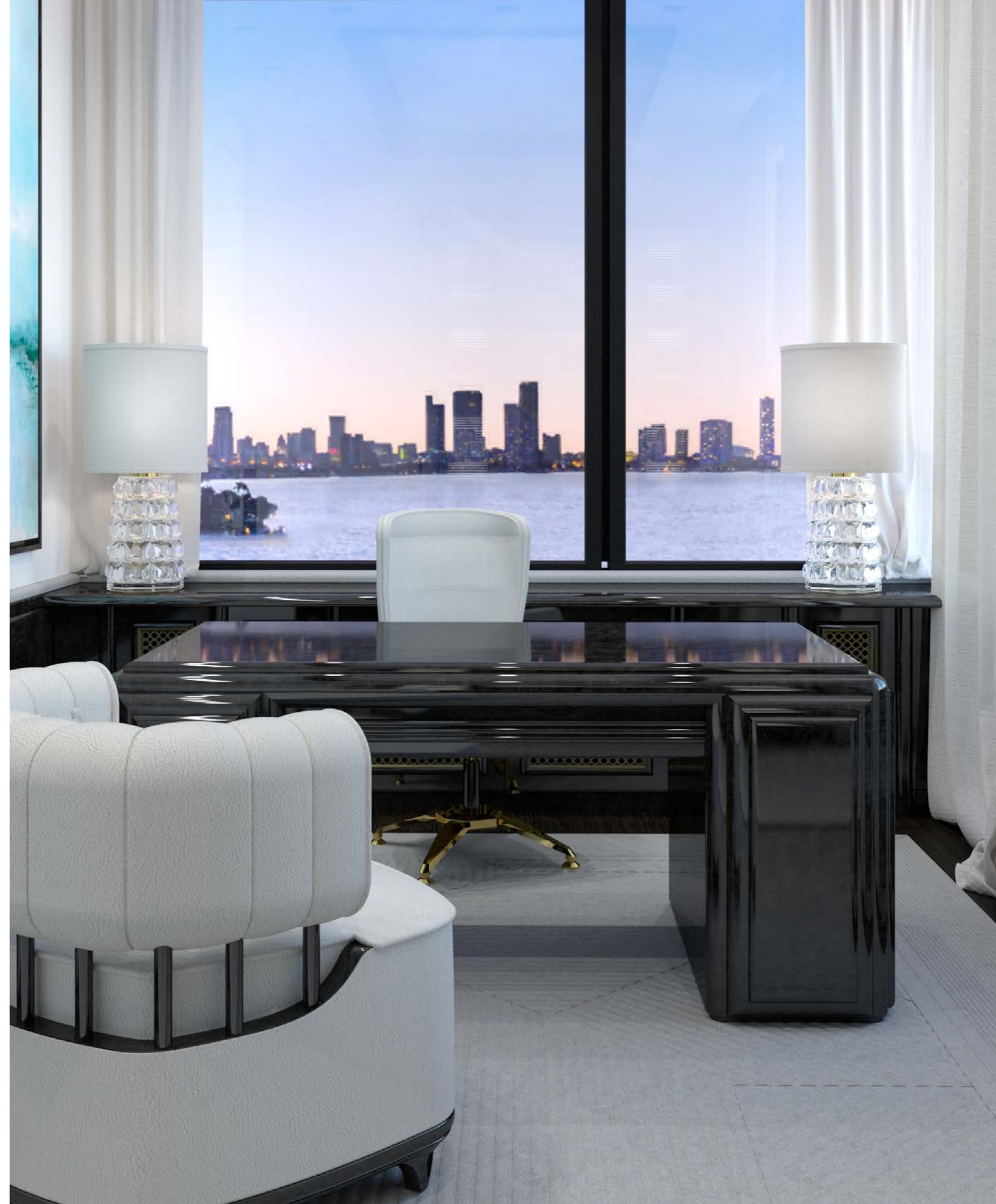



PRIVATE RESIDENCES & ESTATES

STEFANO RICCI has designed special proposals for exclusive residences and estates in a "Made in Italy" context. Luxurious yet welcoming and convivial, stylised and strictly handcrafted, these spaces are as exquisitely sophisticated as the company of people with whom one enjoys sharing time.

Distinctive design elements are prominent parts of each proposal. These include four-metre arches in monolithic pietra serena sandstone, a seven-metre crystal dining table with Californian briar-root wood details and carefully crafted *Granduca* line capitonné couches and armchairs made of fine cashmere specially fitted with over 1200 buttons per chair.

Flooring and cornices are contrasted with materials ranging from Italian oak, pietra serena and white Carrara marble. Rough surfaces meet elegantly smooth details in perfect harmony thanks to the Tuscan travertine's four signature finishes: *lucido*, *bocciardato*, *spazzolato* and *scorza*. In the pursuit of creating a unique ambient from a single piece of wood or stone, Stefano Ricci imagined solid oak doors as well as carved sinks and portals in solid blocks of marble. These emblematic materials find their culmination in full marble bathrooms with modern light fixtures.



SR HOME living room and dining room proposals,
featuring a custom-fit *Black briar-root wood* wine cabinet.





SR HOME living room proposal featuring *Black briar-root wood* consoles.





BELVEDERE COUCH

Part of a versatile design concept at home with both classic and contemporary aesthetics, the *Belvedere* line is a synthesis of architectural imagination and modern comfort. The geometric linework and bold proportions of the *Belvedere* line truly make each item a beautiful viewpoint in the context of the home. The Made-to-Measure *Belvedere* couch is constructed with soft goose down and fabric cushions contrasting the smooth body of the furniture with stunning, horizontal moulded leather seams.





SR HOME bedroom proposal featuring a *Belvedere* line headboard and coordinated door.



**CHISELLED LIGHTING OCTAGON LAMP
& CEILING FIXTURE**

Both the *Chiselled Lighting* octagon lamp and ceiling fixtures feature lightweight plexiglass bases that artisans have chiselled to integrate the modern material with the SR aesthetic. Due to the versatile nature of the material, these lamps and lighting fixtures are available in a variety of colours.

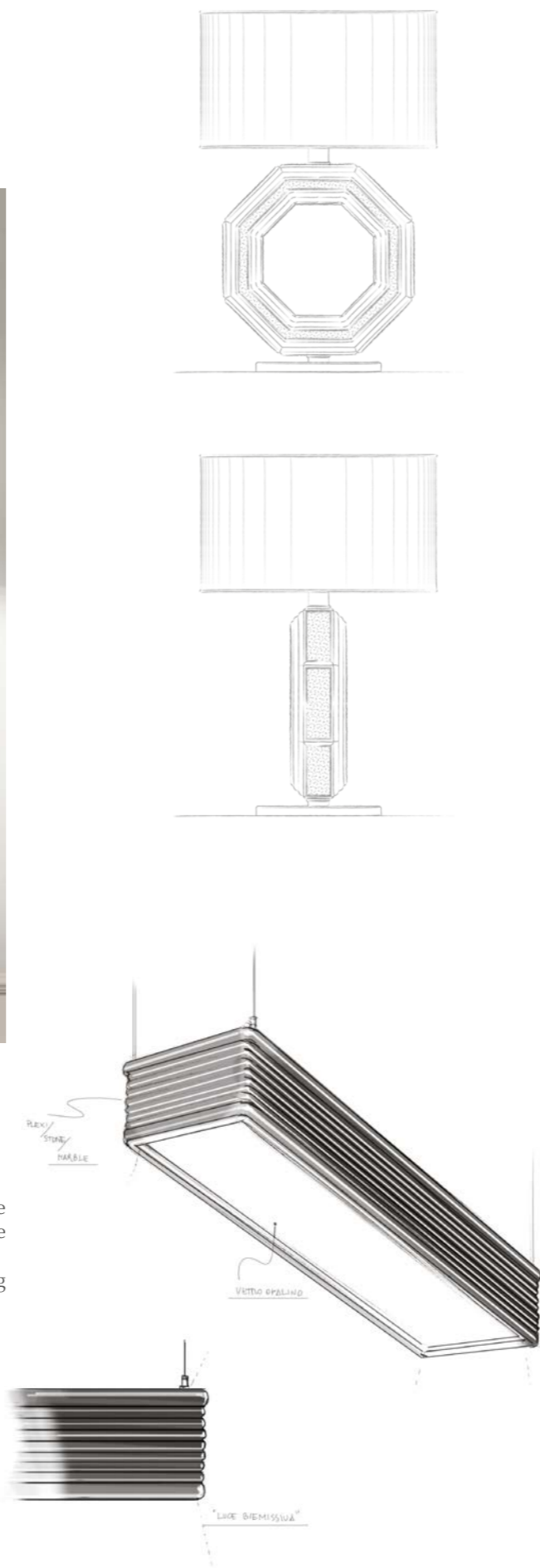



PURE CRYSTAL ACCENT TABLE

The *Pure Crystal* accent table has two layers of clear crystal set into two supporting bases, which may be crafted from brown or black Californian briar-root wood. The crystal shelf under the tabletop may be replaced with a shelf of Pietra serena, travertine or Carrara marble.

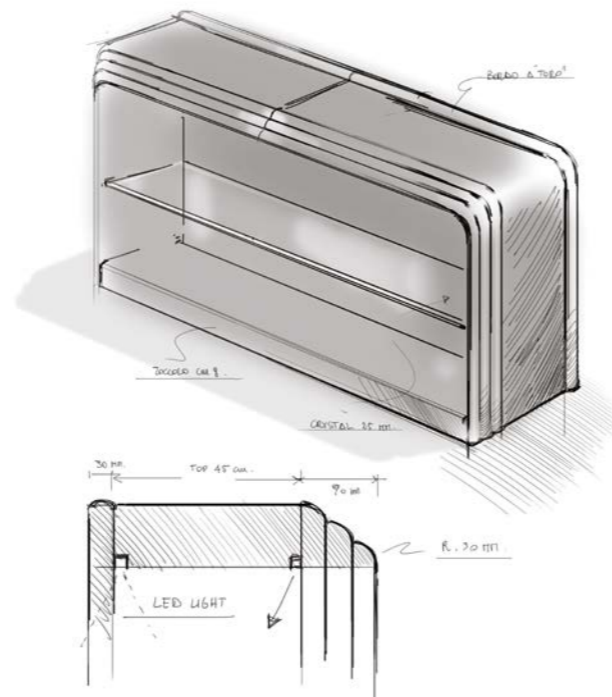

BRIAR-ROOT WOOD CONSOLE

The *Briar-root Wood* console is crafted in either classic brown or contemporary black Californian briar-root wood and has one crystal shelf. The wall console may be personalised with internal light fixtures.





SR HOME dining room proposal featuring a *Pure Crystal* dining table, *Briar-root Wood* wine cabinet and *Chiselled Lighting* ceiling fixtures.



SR HOME proposals, featuring *Signoria* dining chairs and a *Pietra serena* kitchen island with a *Nero Marquina* marble tabletop.

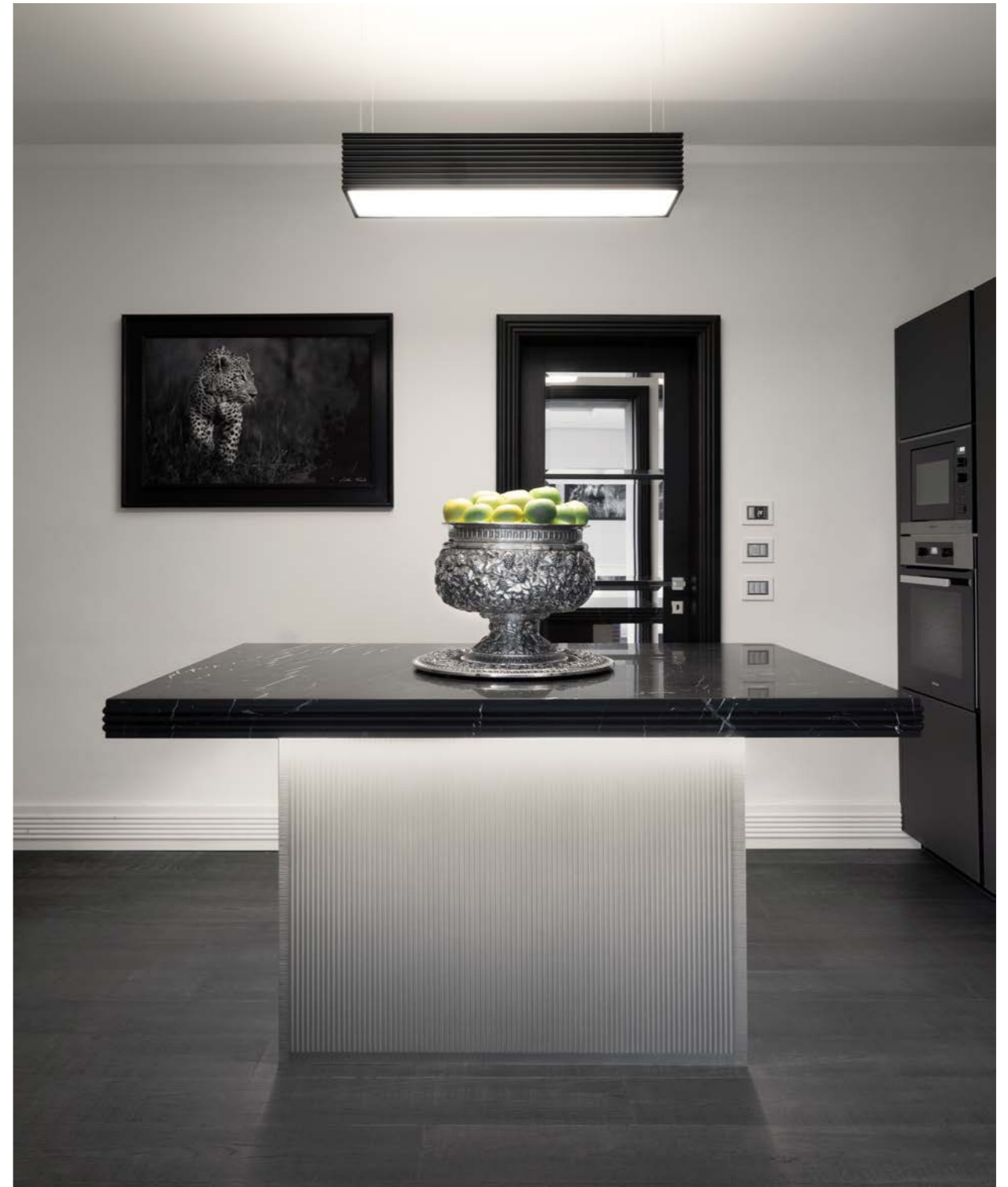





SR HOME living room proposals, featuring a *Pietra Serena* fireplace and a stunning monolithic arch.



LOGGIA TUB CHAIR & COUCH

Emblem of Florentine Mannerism, the *Loggia* line combines the solidity of architecture with humanistic and familial values. Furniture in the *Loggia* line is virile and yet at the same time delicate.

The *Loggia* couch is a sophisticated two-seater in its extended version. The unique base does not have a separate cushion, allowing it to acquire a formal weight that softens and lightens at the junction of the columns. The *Loggia* Line also features a tub chair, which is a harmonious complement to the couch. Enhanced with contrast piping and carefully handmade capitonné work, *Loggia* furniture elegantly fits into any refined interior.





HOME LIBRARIES

The STEFANO RICCI home libraries are an open book of possibilities. They can be customised and constructed with a variety of designs to fit every unique location and aesthetic. Like the *Finished Stone* library, these constructions may be entirely built-in, even in complex spaces such as fireplaces with integrated bookshelves. All materials used in the home lines may be considered, from Californian briar-root wood and pietra serena to travertine and Carrara marble with accents in pure crystal. Internal shelf illumination may also be customised for each project.

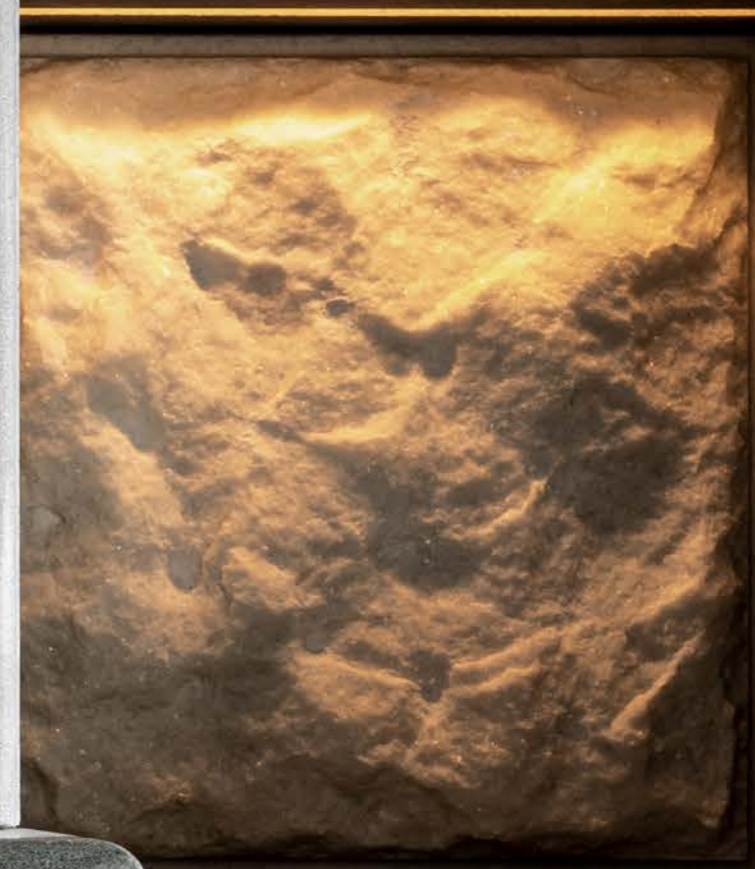



SR HOME dining room proposals featuring *Pure Crystal* and *Finished Stone* dining tables.





SR HOME living room proposals featuring *Pietra Serena* fireplaces and the *Granduca* line furniture.

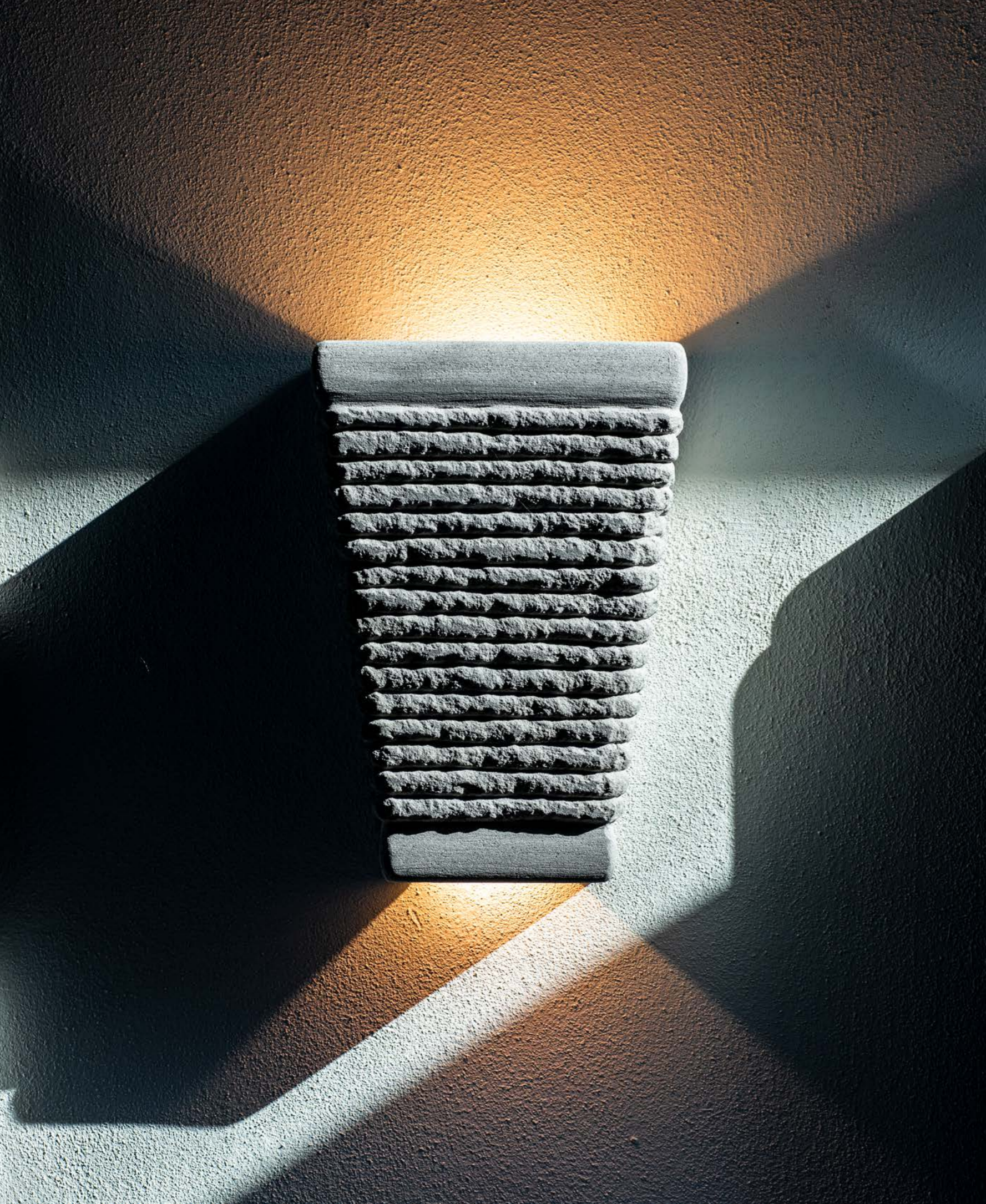





SR HOME bedroom proposals featuring *Tuscan Full-travertine* headboards.

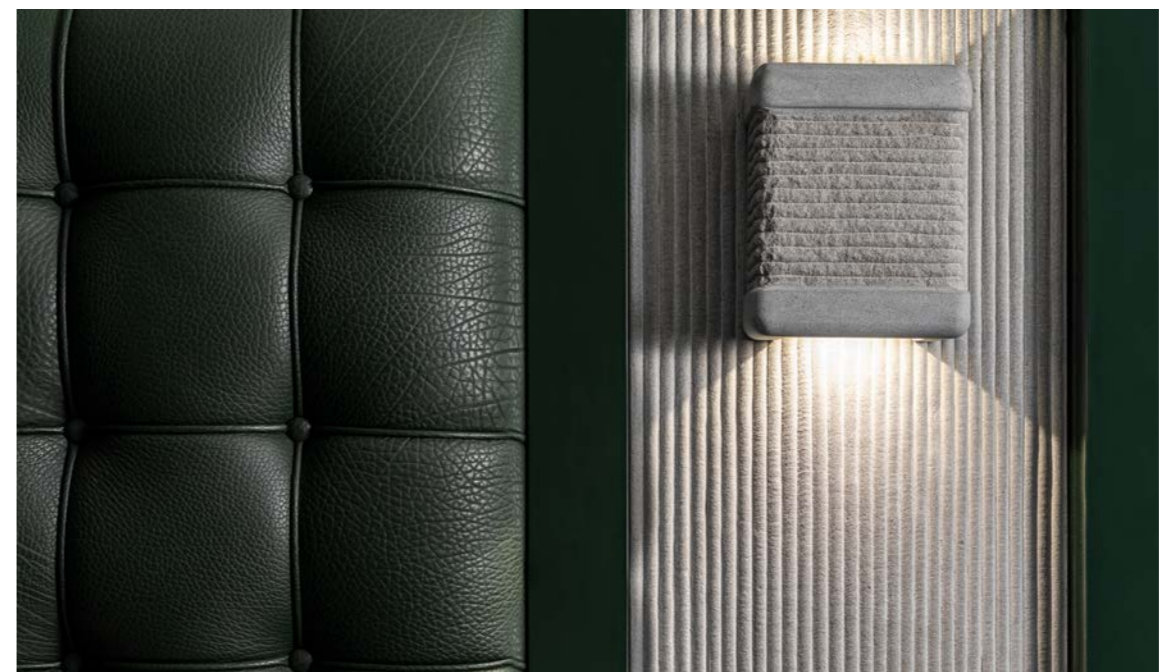

SR HOME bedroom proposal featuring a *Granduca* capitonné headboard.



SR HOME bathroom proposals featuring a variety of design concepts and precious materials.



SR HOME proposal featuring a *Tuscan Full-travertine* bathroom.



HOTEL SUITES & LOUNGES

STEFANO RICCI introduces exclusive interiors for elegant spaces, including luxury hospitality and gourmet restaurants.

These proposals feature distinctive designs for those who see their personalities and exclusive tastes reflected in unique elements that embrace comfort and style for the modern age. From the bar and cigar lounge to the private club parlour, these areas are an integral part of the traveller's journey to elegance.

The design concepts respect and integrate with the aesthetics of the most luxurious hotel partners. From Art Deco-inspired designs to open, airy proposals and intimate indoor/outdoor concepts, each commercial structure is a collaboration between the SR world and the business visionary.

The STEFANO RICCI Presidential Suite
at the Grand Hotel Principe di Piemonte, Viareggio.



Stefano Ricci Presidential Suite at Grand Hotel Principe di Piemonte - Viareggio

On the second floor of the hotel, the signature STEFANO RICCI Suite is characterised by materials that recall the elements of the brand's identity: the contrast between the Californian Briar-root wood surfaces and precious Carrara marbles creates an elegant balance that reflects the image of the iconic boutiques present in international capitals, deriving from a concept inspired by the sea and the yachting world.

Developed in an area of 140 sqm (1507 square feet), the Suite comprises an entrance hall, two bedrooms (the Master equipped with a spa), a living room, a dining room with a wine cellar and three bathrooms. The line that connects the rooms is expressed by sculpted mouldings on the bands of the marble floors, which perfectly connect to the marble tiles in the coffered ceilings and on the passage portals.

Above: The porcelain horse bust fully decorated with platinum and the precious *Antico Setificio Fiorentino* curtains in the "Doria" damask motif.
To the left: View of the octagonal living room of the suite.



Above: The octagonal table made of a Californian Briar-root and marble base and a crystalline top, paired with SR *Signoria* dining chairs.
Opposite page: Close-up on the stained glass of the sliding doors framing the bas-relief of the Grand Hotel Principe di Piemonte.



Above to the left: The *Antico Setificio Fiorentino* silk curtains in a tone on tone ivory "Doria" damask motif embellish the bedrooms.
Above to the right: The octagonal solid plexiglass bedside lamp.
Opposite page: The Master bedroom overlooking the iconic Versilia seafront.



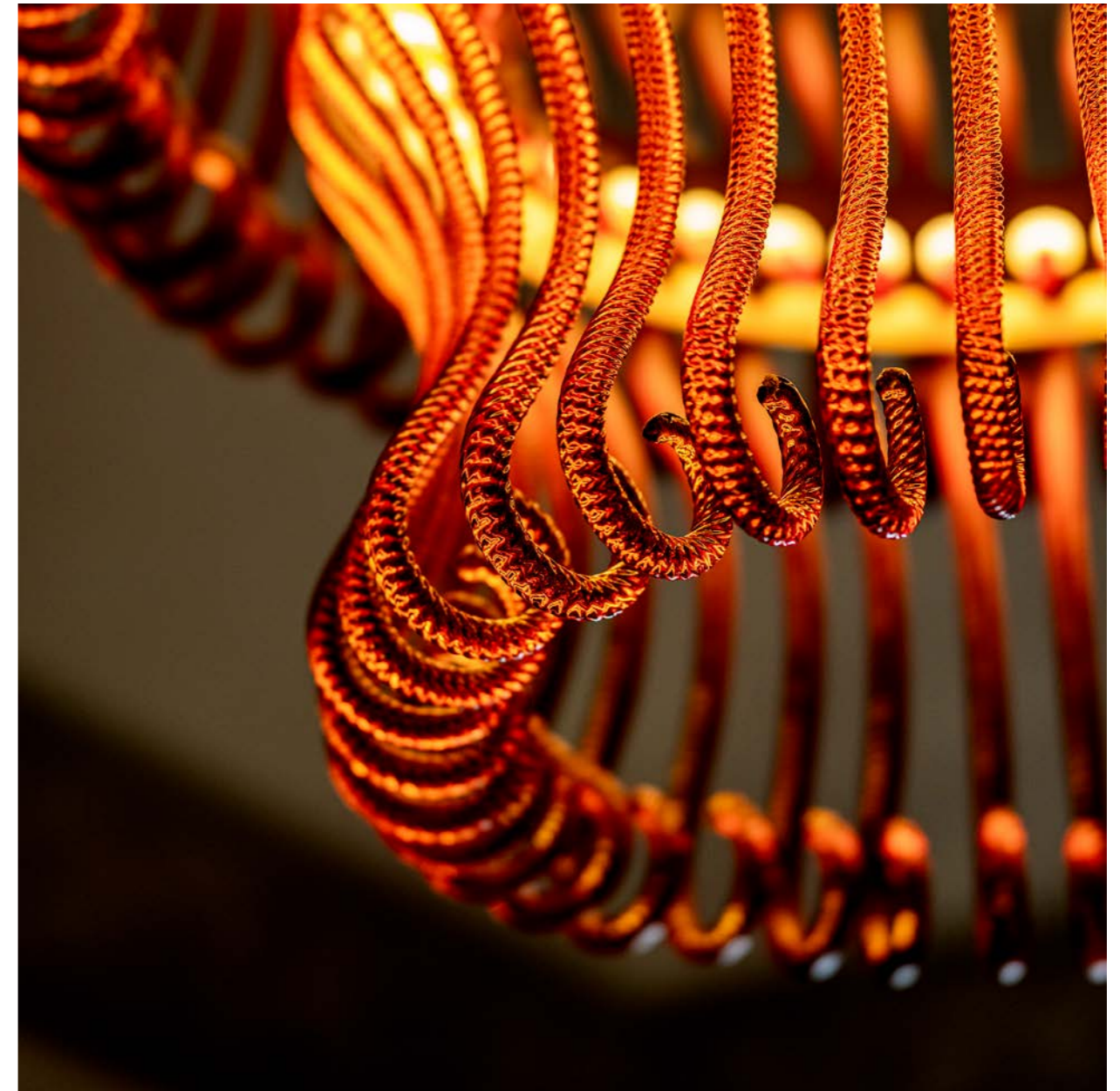

Stefano Ricci La Rocca – Castelfalfi

Nestled in the stunning Tuscan hills, Stefano Ricci La Rocca at Castelfalfi spans 307 sqm across two luxurious levels. The first and second floors each house an elegant Suite, with the upper level featuring a private terrace complete with an outdoor jacuzzi. Dark oak wood floors paired with hand-chiselled pietra serena set a refined tone throughout the bedrooms, living room, and lounge areas. The interiors feature dark walnut furniture with chrome accents, while the lounge's black crocodile leather armchairs add a touch of bold sophistication. Made in rich orange and warm white leather, the beds and seating exude comfort and style. Crystals and solid plexiglass enhance the space through exquisite dining and side tables, complemented by *Antico Setificio Fiorentino* silk curtains and Murano crystal chandeliers. Chalk bas-reliefs add the final artistic touch to this masterpiece of Italian luxury.

Above: A handmade Murano crystal chandelier crowns the suite, casting a warm, refined glow over an atmosphere of timeless Italian elegance.





Above: a studio room part of the SR La Rocca Suite - a space of refined elegance featuring briar-root wood furnishings paired with the majestic Fortezza couch, upholstered in luxury quilted leather.
On the right: the living room space overlooks the beautiful Tuscan hills. The interiors are embellished with SR Home porcelain figures, the iconic Loggia couch and the exclusive Antico Setificio Fiorentino damask curtains.





Above: the two bedrooms of SR La Rocca Suite feature warm dark tones of wood and leather that play with the materials' texture and convey a sense of deep elegance. Each detail recalls the iconic symbols of the Florentine brand.



Stefano Ricci Shanghai Mansion

The Shanghai Mansion offers experiences designed for those who want to enjoy the exclusivity of a place for business lunches or meetings, intimate dinners served by Starred chefs, private cigar experiences, and other tailored events and bespoke privileges. The SR Shanghai Mansion is located in the center of Shanghai, in the former Sino-Soviet Friendship Mansion, with access supervised by a premium security service.

Above: a lounge room inside the SR Shanghai Mansion featuring crocodile leather two-seater couches, briar-root wood furnishings and paneling and SR Cigar line accessories.





The Bar & Lounge Area inside Casa Stefano Ricci Singapore.

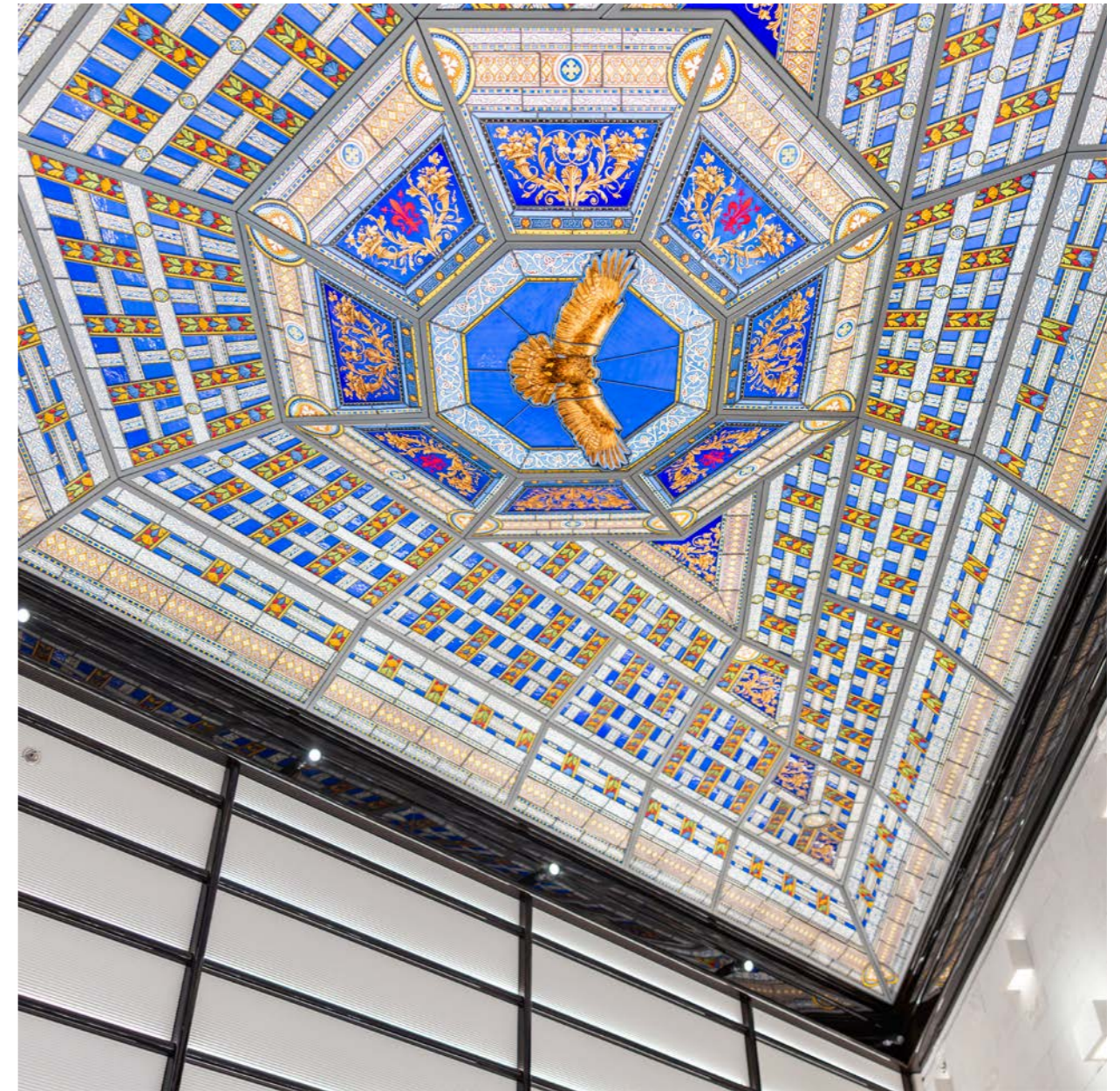

Casa Stefano Ricci Singapore

The total surface area is 340 sqm, and it is located on the eleventh and last floor of the building. The space is divided by a common area, a wine and cigar room, a series of private rooms with floor-to-ceiling windows overlooking Orchard Road, the most famous and exclusive avenue in Singapore. The main space, the common area of the bar, is characterized by a stained-glass ceiling almost 6 meters high. The glass ceiling was produced in Florence and is made up of hundreds of hand-painted pieces.

The interiors are characterized by *Acqua Bianca* marble coverings (featuring a fine grain and pure white colour), walnut briarwood furniture, and walls of the same marble, each one chiselled and hand-crafted.

Above: The stunning artistic glass ceiling crafted in Florence using the ancient know-how. Each glass panel has been hand-placed by master craftsmen to create a unique visual design that recalls ancient Italian buildings.





Above: in the artistic Mellini laboratories, in Florence, the skylight created for the Singapore SR Lounge comes to life. On the right: the reception area of Casa Stefano Ricci Singapore, an exclusive members-only hospitality area created for gentlemen who expect the best.



Casa Stefano Ricci Beijing

The Casa Stefano Ricci in Beijing, accessible from the street or the hotel, is 380 sqm and is set inside the capital's Ritz Carlton in Chaoyang District. The space is divided into a common area, a wine and cigar room, a kitchen and a series of private rooms. The lounge features hand-stained glass windows produced in Florence and furnishings in walnut and white marble. Walls feature Art-Deco bas-reliefs depicting animals such as panthers, elephants, tigers and lions, all designed by Stefano Ricci.

The SR Cigar line presents refined accessories for real connoisseurs: from cigar cutters and precious lighters to luxurious ashtrays and humidors, each piece is an expression of the art of leisure.







Each lounge room is elevated briar-root wood paneling, chiselled *Pietra serena* walls and flooring details and iconic Stefano Ricci furniture pieces. The elephants-design bas-relief and the octagonal elements perfectly complement the ambiance.



Sindalah Yacht Club designed by Stefano Ricci

The Sindalah Yacht Club designed by Stefano Ricci is set amidst the enchanting backdrop of Sindalah Island. It is an exclusive 1800 sqm space embodying the epitome of sophistication. Nestled on the Southeast side of the island, the Yacht Club invites guests on an immersive journey into pure Italian luxury and lifestyle. Sindalah is an unparalleled luxury destination, designed by architect Luca Dini, boasting an 86-berth marina and 75 offshore buoys.

A dedicated SR Cigar Bar and SR Lounge add exclusivity to this space. Ascending to the first floor, the Restaurant features an elegant, coffered ceiling inspired by Florentine Renaissance architecture, complemented by hand-woven textiles from Antico Setificio Fiorentino, an 18th-century silk manufacturing workshop set in the heart of Florence. The terrace, featuring an exclusive area for SR Cigar enthusiasts, offers panoramic views of Sindalah's mesmerising surroundings.



Above: a side view of the Sindalah Yacht Club Bar & Lounge Area. The bar was crafted in the shape of a ship's mast and features an elegant white marble countertop and a *Sindalah Blue* structure in briar-root wood. The combination of the two materials is an iconic interior design element for Stefano Ricci. On the left: the *Fortezza* Bar Stools and the *Loggia* Tub Chair upholstered in *Sindalah Blue* crocodile leather. These refined seats were crafted to dress the Sindalah Yacht Club with authentic Florentine design elements.



Above: two views of the Sindalah Yacht Club's outdoor lounge area. The space is decorated with sofas and armchairs in a wooden-and-cord frame with waterproof sponge upholstery, all bespoke Stefano Ricci. The leather cushions are decorated with the eagle head motif and the outdoor bar is crafted from white and *Sindalah Blue* marble. Guests can also enjoy a pool overlooking the mesmerising Red Sea.



SIGNORIA WINGBACK ARMCHAIR

The *Signoria* wingback armchair makes a powerful statement in any room. Following the line's aesthetic, this elegant armchair recalls the influence of Florence's political and artistic past on contemporary culture. Interweaving this concept with the octagon motif, widely recognised as an iconic SR symbol, resulted in an armchair with two internally folded octagons which shape the armrests and wings. The base communicates with the front of the chair, crafted in a classic style and tying it to a dynamic backrest-and-seat structure. This is lightly unbalanced outside in order to bestow the armchair with greater lightness and contemporaneity.



PURE CRYSTAL OCTAGONAL AND CUBE END TABLES

End tables from the *Pure Crystal* line have elegant solid crystal tabletops that are arranged on sturdy bases. The bases come in two formats; a multi-faceted octagonal Californian briar-root base in brown or black, or a modern, linear cube in solid oak. Details such as the iconic eagle head in octagonal frame motif are added as galvanised accessories, available in gold, palladium and ruthenium.





SR HOME private cigar room proposal.



SR HOME private club lounge proposal featuring the *Fortezza* line.



FORTEZZA ARMCHAIR & COUCH

The *Fortezza* line includes an elegant, handmade armchair and couch finished in Californian briar-root wood with brass details. These models may be upholstered using the capitonné technique in exclusive leathers or fine fabrics, and may be customised for length. The refined quilted leather upholstery is meticulously hand-stitched as a sign of the best artisanal expression.







FORTEZZA BAR STOOLS

The *Fortezza* line continues with eye-catching bar stools sporting leather seat cushions with hand-quilted details, rounded armrests and a contoured backrest envisioned for comfort. The column of each stool has a Californian briar-root wood veneer, an octagonal base, and is embellished with a semi-octagonal galvanised footrest.



SR HOME hotel hall and suite proposals.





SR HOME hotel suite proposals: living and dining rooms.



SR HOME hotel suite proposal.





SR HOME hotel corridor and cellar proposals.





SR HOME indoor/outdoor proposal featuring *Pietra Serena* flooring.







SR HOME outdoor terrace proposal featuring a *Pietra Serena* picnic table and benches.

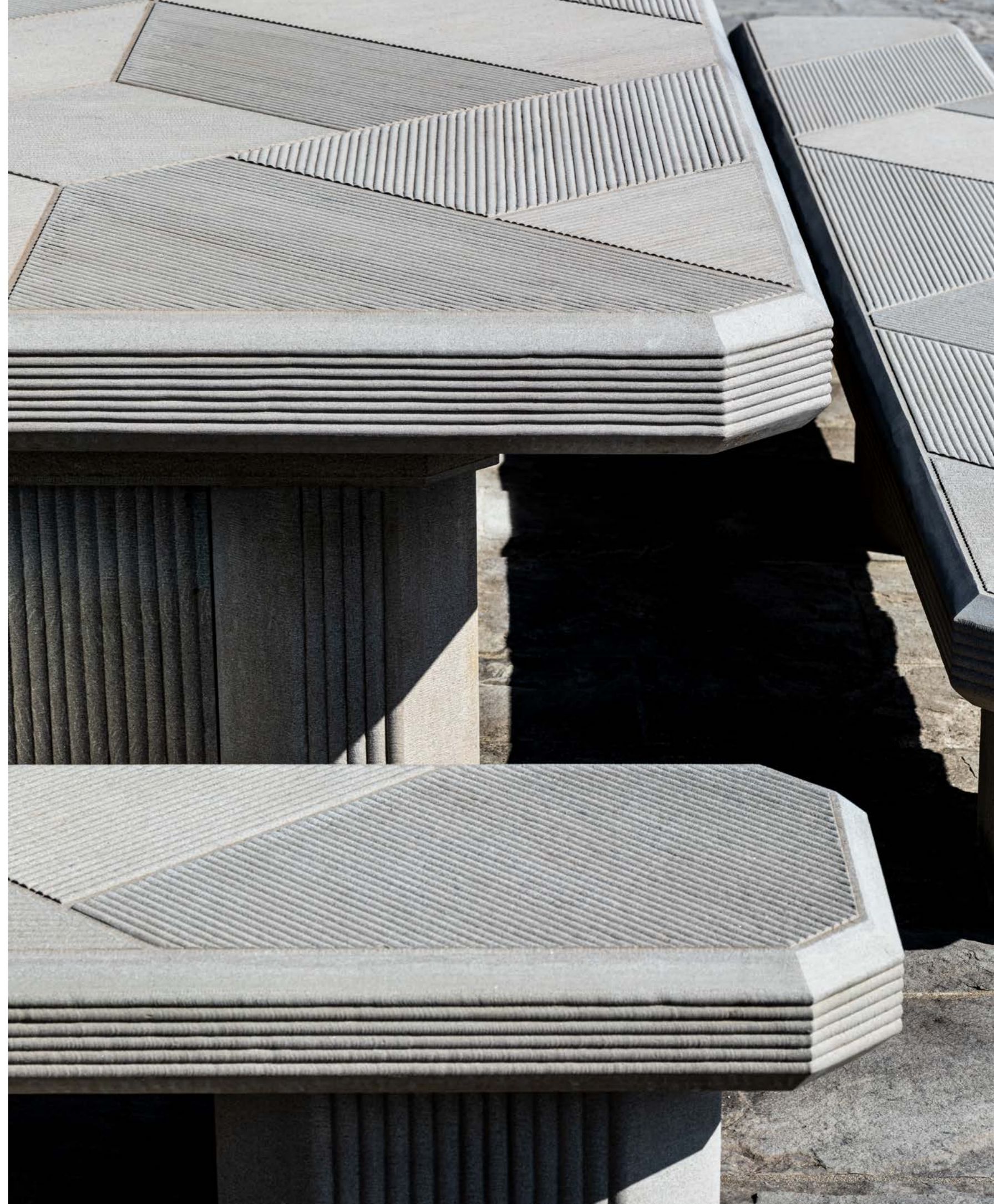

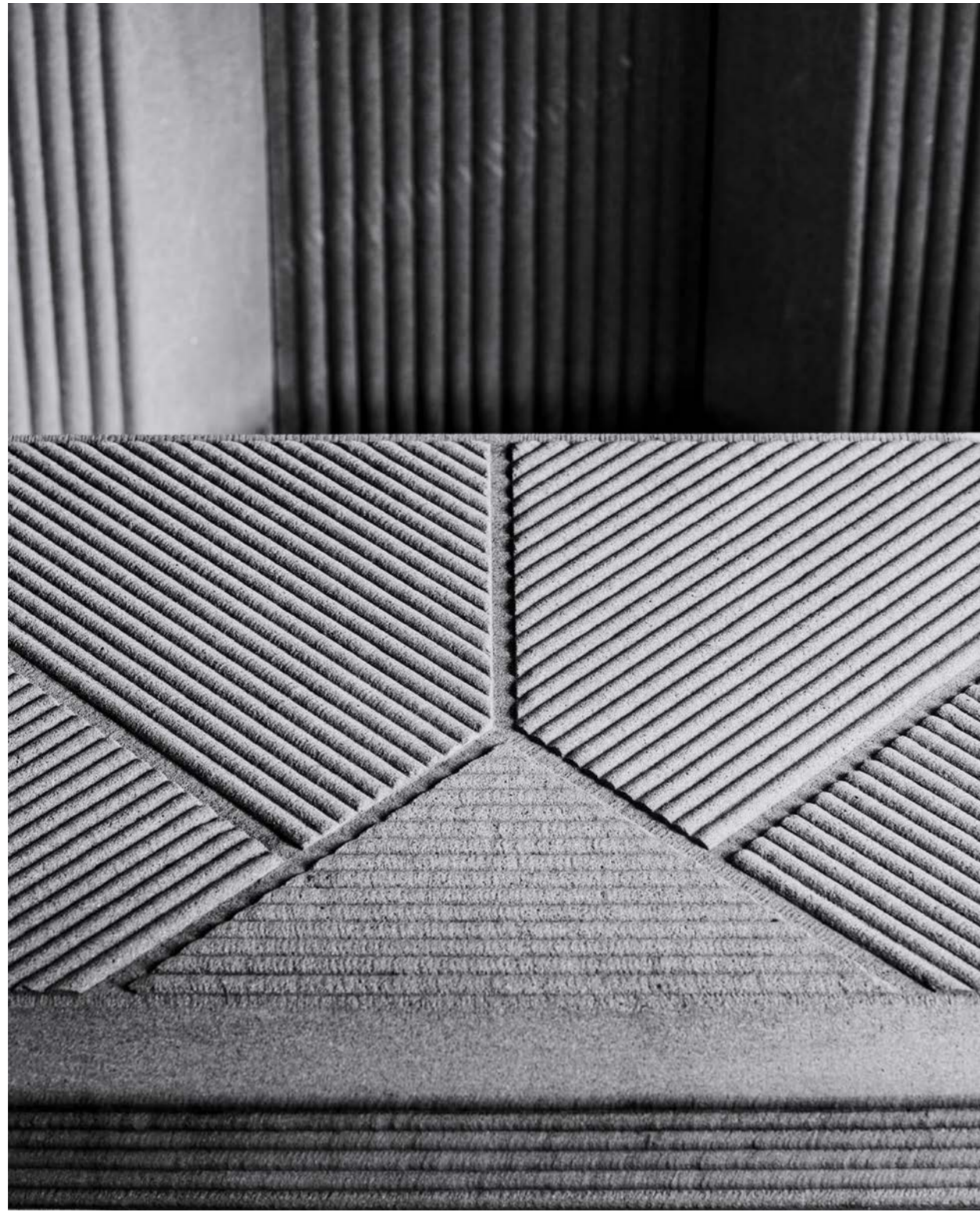

STEFANO RICCI HOME

INTERIOR DESIGN



DISCOVER MORE

© 2026 Stefano Ricci S.p.A.

*All rights reserved under international conventions and laws.
No part of this publication may be reproduced in any way without the prior consent of STEFANO RICCI S.p.A.*



